



**SMF Germany**  
**Specifications for InfraRed**  
**Halogen Heater Lamp**

**JHS 240V 2500W 675 BfH**

**EM-983**

Date: 06-12-06

**CUSTOMER AGREEMENT**

Section	Engineering	Quality
Date	06-12-06	06-12-06
Signature	DEMANGEON Olivier 	DIDIER Benoit 

**TOSHIBA LIGHTING PRODUCTS (FRANCE) S.A**

<p><b>Caution</b></p> <ul style="list-style-type: none"> <li>- Use infrared heater lamp(s) with approved appliances with safety structure as well as safety devices.</li> <li>- Avoid over voltage situation (cause of short lifetime and fire).</li> <li>- Do not place an operating infrared heater lamp(s) close to flammable materials (cause of fire).</li> <li>- Ensure the power supply is disconnected before accessing the infrared heater lamp(s) in alliances (caused of electric shock).</li> <li>- Do not drop, hit, and stress infrared heater(s) and its wire-harnesses mounted with excessive force or vibration, and do not scratch infrared heater lamp glasses (cause of injure, breakage and short-circuit).</li> <li>- In case of an infrared heater lamp(s) being broken, do not handle scattered glass fragments with bare hand (cause of injure).</li> <li>- Do not use the infrared heater lamp(s) which is not explosion-proof product(s) under flammable gas or organic solvent environment (cause of explosion, ignition and fire).</li> </ul> <p><b>Attention</b></p> <ul style="list-style-type: none"> <li>- Infrared heater lamp(s) becomes extraordinarily hot to emit strong infrared radiations around their environment during operation. Ensure safety before the start of the operation.</li> <li>- Operate the infrared heater lamp(s) inside the nominal voltage and maximum wattage density instructed (cause of short lifetime).</li> <li>- Follow the infrared heater lamp(s) burning orientation strictly in its specifications (cause of short lifetime and fire).</li> <li>- Never touch infrared heater lamp(s) in operation or even just after being operated (cause of skin burn).</li> <li>- Do not use infrared heater lamp(s) under water, high humidity or corrosive environment (cause of short lifetime).</li> <li>- Do not gaze an operating infrared heater(s) (cause of eye damage).</li> </ul>	<ul style="list-style-type: none"> <li>- In order to keep the quartz tube in good condition, do not handle infrared heater lamp(s) tube with bare hands. Use clean cloth impregnated with ethyl alcohol to wipe spot gently, if necessary (cause of short lifetime).</li> <li>- Infrared heater lamp(s) shall be fixed and retained firmly inside appliances (cause of drop and breakage).</li> <li>- Do not exceed permissible temperature of the wire-harnesses mounted on infrared heater lamp(s).</li> <li>- Used infrared heater lamp(s) shall be disposed as an industrial waste on the user's responsibility.</li> </ul> <p><b>Notice</b></p> <ul style="list-style-type: none"> <li>- Consult when infrared heater lamp(s) is to be used in vacuum environment.</li> <li>- Consult when infrared heater lamp(s) is to be operated at more than the recommended voltage in the article 3 (Operating infrared heater lamp(s) at a higher than nominal voltage causes a blackening on inner wall of glass tube by excess tungsten vapor. Paradoxically however operating lamp at a lower voltage leads to insufficient temperature of optimum value for the filament, and excess gas may damage the filament. Such operations may therefore result to shorten lamp life).</li> <li>- Although there is some case to enable to observe a browning on the both end of infrared heater lamp (s) after use, this phenomena does not influence the performance of infrared heater lamp(s).</li> <li>- The approval from the customer for the specifications, cautions, attentions and notices for the infrared heater lamp shall be completed in the date of the customer's signature in the front page or the issued date of order sheet from the customer whichever occurs first.</li> </ul>
---	--

**TOSHIBA LIGHTING PRODUCTS (FRANCE) S.A**

--	--

<p>1. Operating condition</p> <p>1-1. Temperature at sealing part: Temperature at both sealing ends (in the quartz glass above the molybdenum foil center) shall be measured with thermo-couple and must not exceed 350°C (to avoid a loss of electrical conductivity caused by molybdenum foil oxidation)</p> <p>1-2. Temperature at glass tube surface: 250 to 900°C</p> <p>1-3. Operating atmosphere: Under normal atmosphere pressure, without corrosive or explosive or inflammable gas.</p> <p>2. Storage environment</p> <p>2-1. Temperature range: -20°C MIN. 70°C MAX.</p> <p>2-2. Humidity range: 10%RH MIN 90%RHMAX without condensation.</p> <p>2-3. Under normal atmosphere pressure, without corrosive gas.</p>	<p>3. Warrantee</p> <p>3-1. Warrantee period: One year after the invoiced date to the customer.</p> <p>3-2. Condition of warrantee: In case of infrared heater lamp(s) with defect (defined as none-conformity to the specifications) is returned from the customer, during the warrantee period, TOSHIBA Lighting products (France) S.A., will compensate with re-delivering good infrared heater lamp(s). There is no obligation if the problem happened due to miss-design of appliances including safety design, miss-usage or miss handling of the infrared heater lamp(s). In case doubts rise up to judge none-conformity to the specifications, both parties shall cooperate together to solve problems.</p>
---	--

Batch code information:

Batch code example

**A 0 6**

Month	Code
Jan	A
Feb	B
Mar	C
Apr	D
May	E
June	G
July	H
Aug	K
Sept	L
Oct	R
Nov	S
Dec	U

Year	Code
2006	06
2007	07
2008	08
2009	09
2010	10
2011	11
2012	12
2013	13
2014	14
2015	15
2016	16
Etc..	

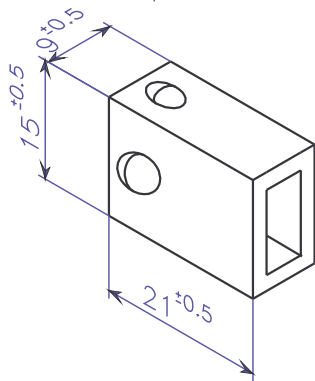
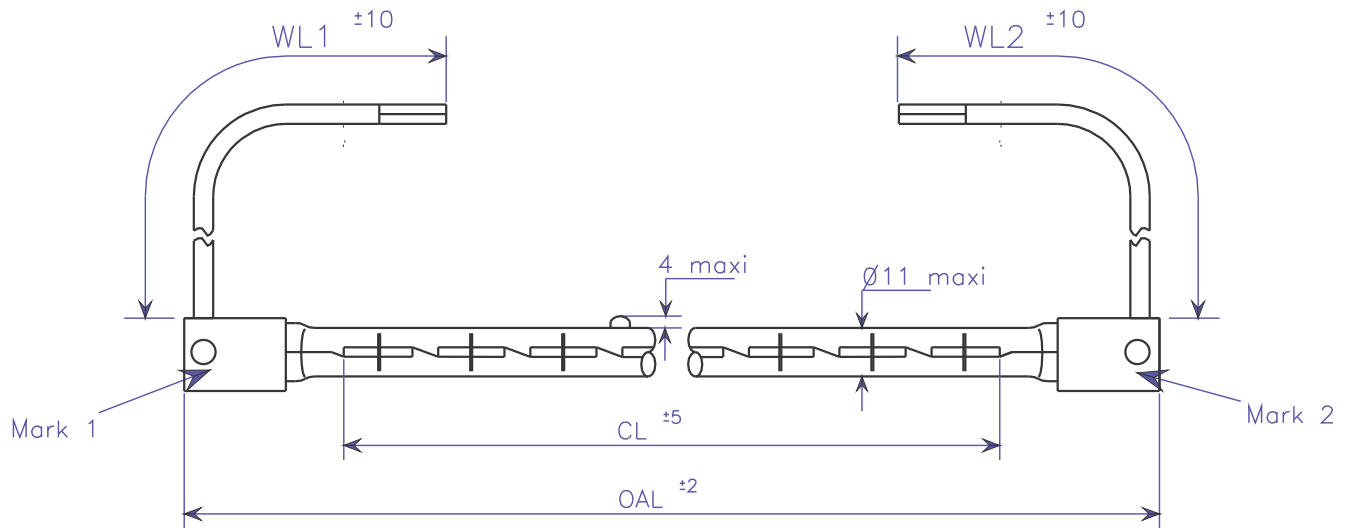

OAL	750	WL.1	800
CL	675	WL.2	800
Mark 1	SMF Germany + lot	Mark 2	240V 2500W

Wire: SILICABLE CNVAS 400°C 1mm<sup>2</sup> Color: grey  
OMERIN or equivalent

Terminal: End stripped (7mm)

Specifications:

Nominal voltage: 240 V

Wattage: 2500 W ± 5%

Average life: should be confirmed into the final machine

Lighting position: Horizontal ± 4°

Tc 2775 K

Strength test:

– Wire harness shall withstand tensile load of 49 N (5 Kgf)

Type: InfraRed Halogen Heater Lamp  
JHS 240V 2500W 675 BfH

Modif.:

Date:

Date:  
04-12-06

TOSHIBA LIGHTING PRODUCTS  
(France) S.A.

Version  
EM-983

Comments